



The 5ml Tree Injector is a precision instrument, with a high standard of finish.
Given normal care it will last indefinitely.

As components in this instrument may be affected by solvents in some commonly used farm chemicals no responsibility will be accepted by the manufacturer should the instrument be used with such products.

INSTRUCTIONS FOR USE

It is essential that this instrument, and a supply of needles, be thoroughly sterilized before each use. A common method of sterilization is as follows:

1. Attach connecting hose to handpiece.
2. Wrap cloth around handpiece and draw hot water into cylinder through connecting hose.
3. Suspend the complete instrument in a container of water and boil, together with the needles, for 10 to 20 minutes.
4. Remove instrument from container, wrap cloth around the handle and pump dry.

NOTE: Suspending the instrument not only makes it easier to remove but also prevents damage should the container boil dry. Repeated boiling will eventually cause the transparent connecting hose to turn cloudy. This is not harmful. Chemical sterilization with antiseptic solutions is sometimes practised and in such instances the recommendations of the chemical manufacturer should be followed. **Do not attempt to sterilize by autoclaving.**

To set the dose:

1. Slacken off dose adjuster lock nut.
2. Rotate threaded dose adjuster until the front piston washer registers with the required calibration on the cylinder.
3. Retighten dose adjuster lock nut. After attachment to the vaccine container hold the instrument vertically (needle upwards) and prime until all air is removed from the cylinder and connecting hose. Presence of excessive air bubbles in the cylinder indicates a loose fitting or damaged piston seal. See instructions for care and maintenance for replacement procedure.

WARNING: Care must be taken to ensure the liquid does NOT come into contact with any part of the operators body. Chemicals may cause injury to the operator.

CARE AND MAINTENANCE After Use

1. Remove all traces of material from instrument by flushing thoroughly with a hot water detergent mix. Follow with clean, warm water.
2. Disconnect feed tube from handpiece and place inlet fitting in NJ Phillips Lubricant, allowing a small quantity of NJ Phillips Lubricant to be pumped through the handpiece.
3. Store with dose set at 2 ml. This is most important as, after being stored for some time, the piston washers may adhere to the cylinder. Setting down to 2 ml does not allow sufficient stroke to damage the washers when the instrument is worked for next use.

To Replace Rubber Washers

1. Slacken off dose adjuster lock nut as far as possible.
2. Undo cylinder clamping nut.
3. Hold needle mount and withdraw push rod cylinder assembly.
4. Remove cylinder before unscrewing piston.
5. Replace 'O' ring, taking care not to damage the groove.
6. Ensure that the raised boss on the piston washer faces to the front and that the support washer is correctly positioned.
7. Insert the piston washer carefully into the transparent cylinder.
8. Removal of the needle mount and head cage is accomplished by easing the cage through the side of the body.
9. To remove the delivery valve first insert a nail in the hole in the valve cage and then unscrew the delivery valve screw. When replacing these parts ensure that the raised boss on the valve washer faces to the front.
10. When re-assembling it is important to make certain that the needle mount is correctly located in the hexagonal hole in the cylinder cage head before re-tightening the cylinder clamping nut.



The 5ml Tree Injector is a precision instrument, with a high standard of finish.
Given normal care it will last indefinitely.

As components in this instrument may be affected by solvents in some commonly used farm chemicals no responsibility will be accepted by the manufacturer should the instrument be used with such products.

INSTRUCTIONS FOR USE

It is essential that this instrument, and a supply of needles, be thoroughly sterilized before each use. A common method of sterilization is as follows:

1. Attach connecting hose to handpiece.
2. Wrap cloth around handpiece and draw hot water into cylinder through connecting hose.
3. Suspend the complete instrument in a container of water and boil, together with the needles, for 10 to 20 minutes.
4. Remove instrument from container, wrap cloth around the handle and pump dry.

NOTE: Suspending the instrument not only makes it easier to remove but also prevents damage should the container boil dry. Repeated boiling will eventually cause the transparent connecting hose to turn cloudy. This is not harmful. Chemical sterilization with antiseptic solutions is sometimes practised and in such instances the recommendations of the chemical manufacturer should be followed. **Do not attempt to sterilize by autoclaving.**

To set the dose:

1. Slacken off dose adjuster lock nut.
2. Rotate threaded dose adjuster until the front piston washer registers with the required calibration on the cylinder.
3. Retighten dose adjuster lock nut. After attachment to the vaccine container hold the instrument vertically (needle upwards) and prime until all air is removed from the cylinder and connecting hose. Presence of excessive air bubbles in the cylinder indicates a loose fitting or damaged piston seal. See instructions for care and maintenance for replacement procedure.

WARNING: Care must be taken to ensure the liquid does NOT come into contact with any part of the operators body. Chemicals may cause injury to the operator.

CARE AND MAINTENANCE After Use

1. Remove all traces of material from instrument by flushing thoroughly with a hot water detergent mix. Follow with clean, warm water.
2. Disconnect feed tube from handpiece and place inlet fitting in NJ Phillips Lubricant, allowing a small quantity of NJ Phillips Lubricant to be pumped through the handpiece.
3. Store with dose set at 2 ml. This is most important as, after being stored for some time, the piston washers may adhere to the cylinder. Setting down to 2 ml does not allow sufficient stroke to damage the washers when the instrument is worked for next use.

To Replace Rubber Washers

1. Slacken off dose adjuster lock nut as far as possible.
2. Undo cylinder clamping nut.
3. Hold needle mount and withdraw push rod cylinder assembly.
4. Remove cylinder before unscrewing piston.
5. Replace 'O' ring, taking care not to damage the groove.
6. Ensure that the raised boss on the piston washer faces to the front and that the support washer is correctly positioned.
7. Insert the piston washer carefully into the transparent cylinder.
8. Removal of the needle mount and head cage is accomplished by easing the cage through the side of the body.
9. To remove the delivery valve first insert a nail in the hole in the valve cage and then unscrew the delivery valve screw. When replacing these parts ensure that the raised boss on the valve washer faces to the front.
10. When re-assembling it is important to make certain that the needle mount is correctly located in the hexagonal hole in the cylinder cage head before re-tightening the cylinder clamping nut.

CARE AND MAINTENANCE *continued*

Lubricating Instructions

If this instrument becomes sluggish in operation, lubrication is probably required behind the piston.

1. Unscrew the dose adjustor until it can be pulled back against the spring and clear of the body.
2. Lubricate the cylinder with four or five drops of NJ Phillips Lubricant.
3. Screw back the dose adjustor to the required dose.

LEGEND:

1. Nozzle Nut, 2. Spray Nozzle, 3. Delivery Valve Cage, 4. Head Seal Washer, 5. Plunger Washer, 6. Cup Support Washer, 7. Delivery Valve Screw, 8. Cylinder Cover, 9. Finger Grip, 10. Barrel Lock Ring, 11. Cylinder, 12. Plunger Washer, 13. Cup Support Washer, 14. Piston, 15. Piston Seal Ring, 16. Cylinder Lock Nut, 17. Dose Adjustor Lock Nut, 18. Dose Adjustor, 19. Return Spring, 20. Spring Cover Plate, 21. Push Rod Assembly.

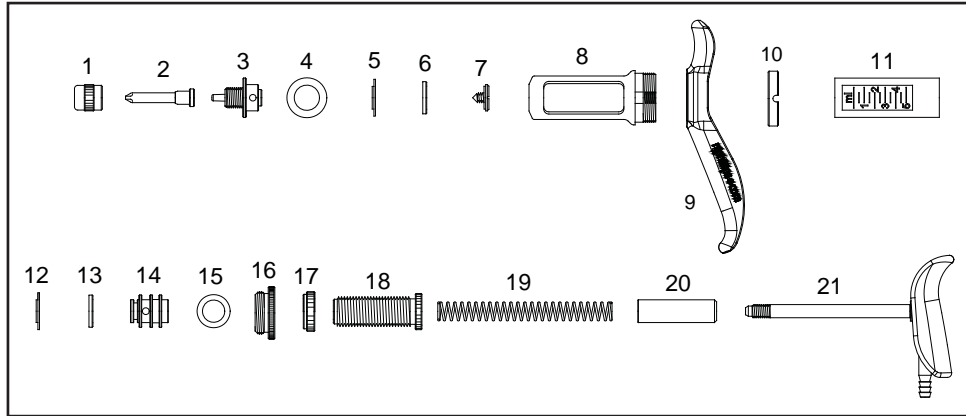

PLEASE ORDER BY KIT AND PART NAME.

SPARE PARTS AVAILABLE:

KIT No.	PART NAME	INCLUDES ILLUSTRATION No.
WX110	Major Service Kit	4,5,6,11,12,13,15.
WX260	Minor Service Kit	4,5,6,12,13,15.

CARE AND MAINTENANCE *continued*

Lubricating Instructions

If this instrument becomes sluggish in operation, lubrication is probably required behind the piston.

1. Unscrew the dose adjustor until it can be pulled back against the spring and clear of the body.
2. Lubricate the cylinder with four or five drops of NJ Phillips Lubricant.
3. Screw back the dose adjustor to the required dose.

LEGEND:

1. Nozzle Nut, 2. Spray Nozzle, 3. Delivery Valve Cage, 4. Head Seal Washer, 5. Plunger Washer, 6. Cup Support Washer, 7. Delivery Valve Screw, 8. Cylinder Cover, 9. Finger Grip, 10. Barrel Lock Ring, 11. Cylinder, 12. Plunger Washer, 13. Cup Support Washer, 14. Piston, 15. Piston Seal Ring, 16. Cylinder Lock Nut, 17. Dose Adjustor Lock Nut, 18. Dose Adjustor, 19. Return Spring, 20. Spring Cover Plate, 21. Push Rod Assembly.

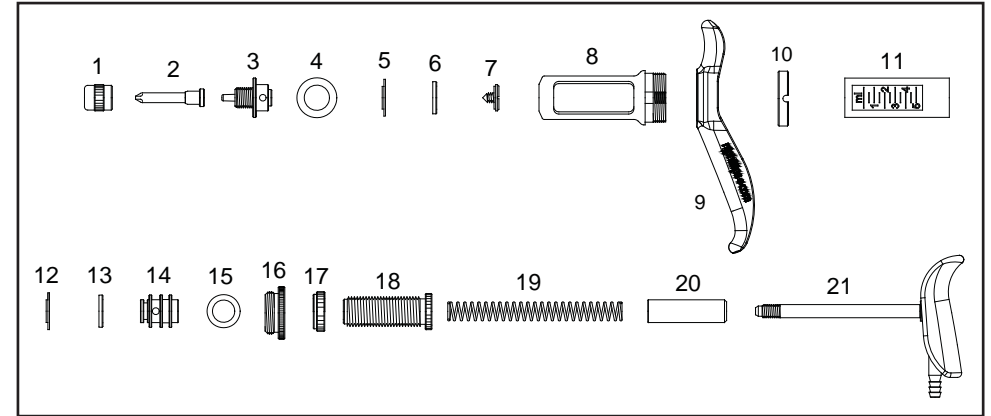

PLEASE ORDER BY KIT AND PART NAME.

SPARE PARTS AVAILABLE:

KIT No.	PART NAME	INCLUDES ILLUSTRATION No.
WX110	Major Service Kit	4,5,6,11,12,13,15.
WX260	Minor Service Kit	4,5,6,12,13,15.

AS OUR POLICY IS ONE OF CONTINUOUS IMPROVEMENT THE MANUFACTURER RESERVES THE RIGHT TO ALTER THESE SPECIFICATIONS AT ANY TIME. ALL PRODUCTS PRODUCED BY NJ PHILLIPS PTY LIMITED, ARE IDENTIFIED BY A UNIQUE BATCH NUMBER. THIS IDENTIFICATION NUMBER IS AFFIXED TO THE PRODUCT TO ALLOW TRACEABILITY BY THE MANUFACTURER AND MUST NOT BE REMOVED IF PRODUCT INTEGRITY IS TO BE MAINTAINED.

	NJ PHILLIPS Pty Limited ABN 36 000 082 002		
	POSTAL ADDRESS: LOCKED BAG 8 GOSFORD NSW 2250 AUSTRALIA		
	TELEPHONE: (02) 4340 2044 FAX: (02) 4340 1991		
	EMAIL: njp1@njphillips.com.au		

MADE IN AUSTRALIA

njphillips.com

QL732

AS OUR POLICY IS ONE OF CONTINUOUS IMPROVEMENT THE MANUFACTURER RESERVES THE RIGHT TO ALTER THESE SPECIFICATIONS AT ANY TIME. ALL PRODUCTS PRODUCED BY NJ PHILLIPS PTY LIMITED, ARE IDENTIFIED BY A UNIQUE BATCH NUMBER. THIS IDENTIFICATION NUMBER IS AFFIXED TO THE PRODUCT TO ALLOW TRACEABILITY BY THE MANUFACTURER AND MUST NOT BE REMOVED IF PRODUCT INTEGRITY IS TO BE MAINTAINED.

	NJ PHILLIPS Pty Limited ABN 36 000 082 002		
	POSTAL ADDRESS: LOCKED BAG 8 GOSFORD NSW 2250 AUSTRALIA		
	TELEPHONE: (02) 4340 2044 FAX: (02) 4340 1991		
	EMAIL: njp1@njphillips.com.au		

MADE IN AUSTRALIA

njphillips.com

QL732