

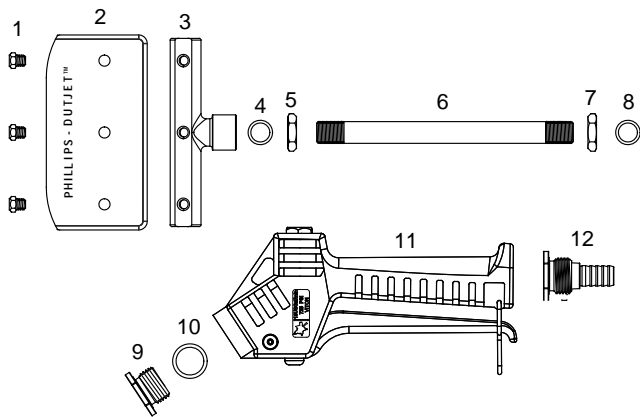

- High flow pour-on application for long wool sheep.
- Easy to clean and maintain and will provide years of service.



PARTS BREAKDOWN



- | | | | |
|----------------------------|------------|----------------------------|----------|
| 1. Jetting Tip | (SN336) | 7. Handle Lock Nut | (SN335) |
| 2. Jetting Shroud | (SP664) | 8. Handle Seal Ring | (SP220) |
| 3. T-Bar Delivery Head | (SXM322/A) | 9. Handle Plug | (SM758) |
| 4. Delivery Tube Seal Ring | (SP220) | 10. Handle Plug Seal Ring | (SP75) |
| 5. Delivery Tube Lock Nut | (SN335) | 11. Handle | (SP1297) |
| 6. Delivery Tube | (SM572) | 12. Inlet Adaptor Assembly | (SXM571) |

MODEL DOSE CAPABILITY

DUTJET 10 – 15 litres per minute

KIT NO.	PART NAME	PART NO.
WX1587	Inlet Adaptor Fitting	12.
WX1588	Handle Assembly	9,10,11,12.

PLEASE ORDER BY KIT AND PART NAME



Customise this instrument with your brand colour and logo. Contact us for details.



njphillips.com
Our expertise is in your hands.

LOCKED BAG 8, GOSFORD NSW, AUSTRALIA 2250

P +61 2 4340 2044 F +61 2 4340 1991 | E njp1@njphillips.com.au